



SLRE

INSET RUNWAY EDGE LIGHT



COMPLIANCES

ICAO: Annex 14 - Volume I Fig. A2-9, A2-10

FAA: L-850C-D AC150/5345-46

IEC: TS 61827

NATO: STANAG 3316

CAA: CAP 168

IAAE: TP312

APPLICATIONS

Runway Edge for ICAO CAT I,II and III, FAA and military runways

Used for Threshold/Runway End FAA lighting

BENEFITS

- 1000 hours lamp rated life at full intensity, but over 3000 hours in field operating conditions
- Significant energy saving and stable chromaticity thanks to the use of dichroic filters
- Designed and manufactured with simplicity and easy to maintain
- No use of sealant to fix the prisms in the dome thanks to customized gaskets, making their replacement quick and easy
- No optical adjustment after lamp, filter or prism replacement
- Valve for watertightness test after overhaul
- Dome temperature less than 160°C at 6.6A

PERFORMANCES

- 12.7 mm protrusion
- Bidirectional or unidirectional, 12" dia.
- Cast aluminium dome and lower cover make the fitting sturdy, but lightweight too for ease handling in the field
- The optical channels in front of the prism windows protect the prisms from damages, preventing rubber deposits, scratches and shocks, thereby maintaining an optimal light output and reducing maintenance costs
- O-Ring placed outside the dome to avoid dirt deposits between light and base
- Protection degree: IP67
- Temperature range: -55°C to +55°C

INSTALLATION

- Suitable for 12" dia. bases
- Specific tools available for easy and precise installation

PHOTOMETRIC PERFORMANCES

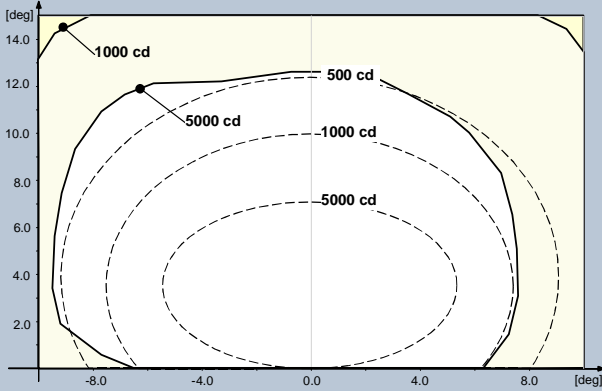

Fig. 1 ICAO A2-9 45 m – White

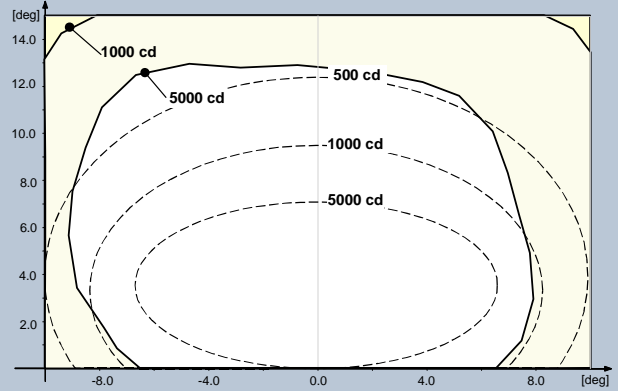

Fig. 2 ICAO A2-10 60 m – White

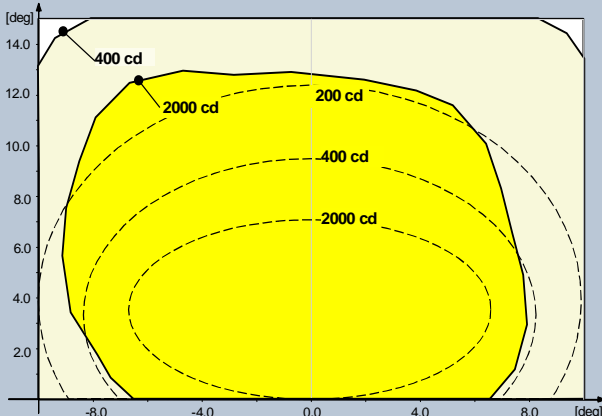

Fig. 3 ICAO A2-10 60 m – Yellow

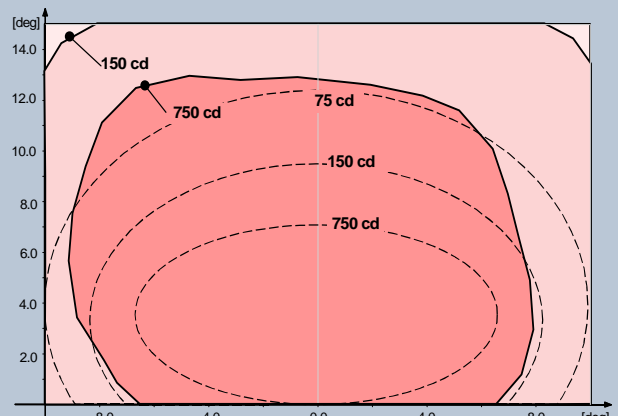

Fig. 4 ICAO A2-10 60 m – Red

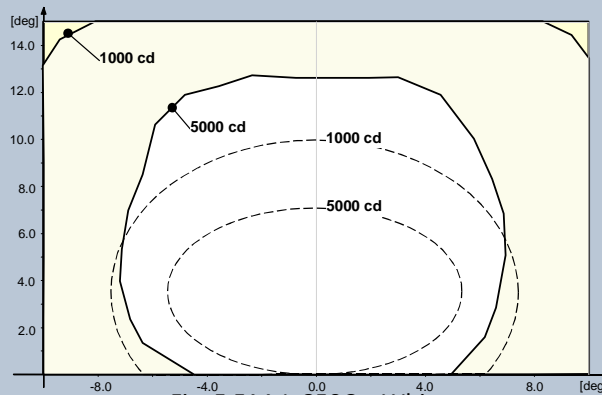

Fig. 5 FAA L-850C – White

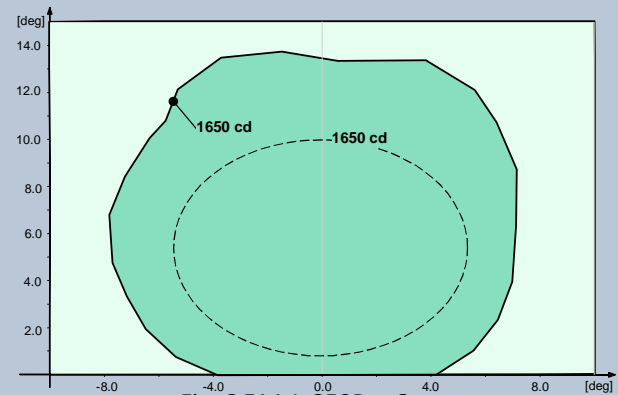

Fig. 6 FAA L-850D – Green

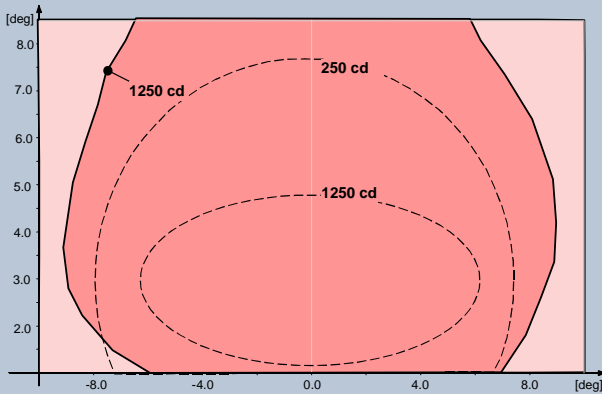
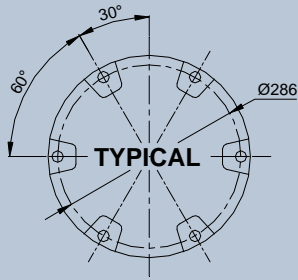
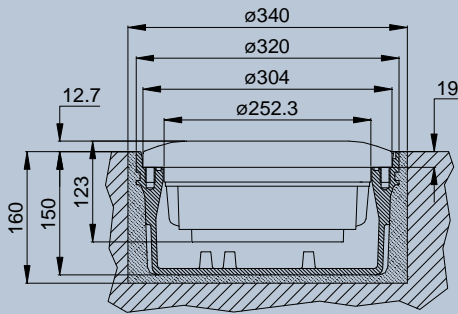

Fig. 7 FAA L-850D – Red



TYPICAL
Light Fixture 12" dia.



Shallow Base 12" dia.

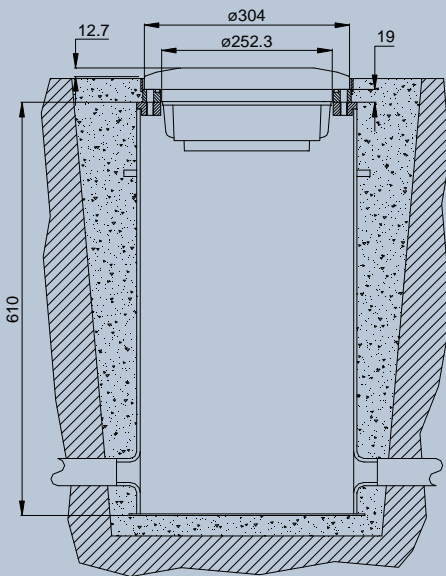

L-868 Deep Base 12" dia.

SLRE- I - CPY - 1P - 200 - O - F

Basic P/N: _____

Compliance: _____

- I = ICAO 60 m Runway Edge
- S = ICAO 45 m Runway Edge
- E = FAA L-850C Runway Edge
- A = FAA L-850D Threshold/End

Colour(Side L)/(Side R)*: _____

- C = White
- R = Red
- Y = Yellow
- G = Green
- X = Screened

Electrical System: _____

- 1P = One Cable Lead
- 2P = Two Cable Leads

Lamps: _____

- 100 = 1x 105 W 6.6A with reflector
- 200 = 2x 105 W 6.6A with reflector

Mounting Assembly: _____

- O = No Mounting Assembly

Options: _____

- F = Fuse Cutouts

* The beam aiming is not field adjustable

The colour of the central beam must be followed by a "P"

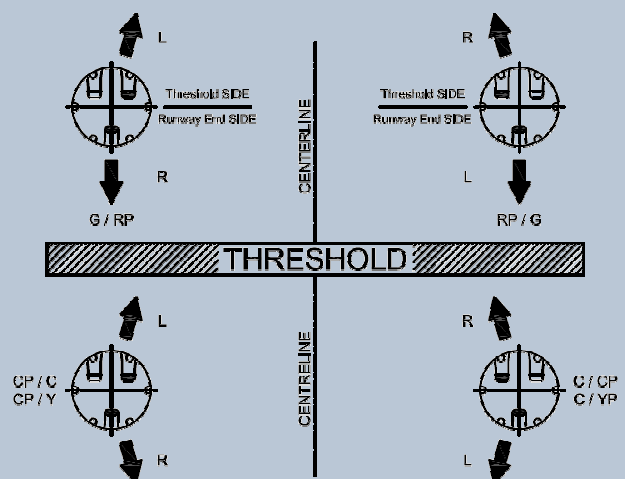

RENEWAL PARTS FOR LIGHT UNIT

- 1 Dome, with prisms and gaskets
- 2 Lamp supporting plate
- 3 Fuse cutout
- 4 Insulated strip with hardware
- 5 Lower cover with plug and valve
- 6 Valve for watertightness test
- 7 FAA L-823 plug
- 8 O-Ring for lower cover
- 9 Lamp
- 10 Prism gasket
- 11 Mounting plate
- 12 Filter
- 13 Nylon gasket
- 14 Prism
- 15 O-Ring for dome

Refer to the relevant technical manual for the complete list of the available spare parts

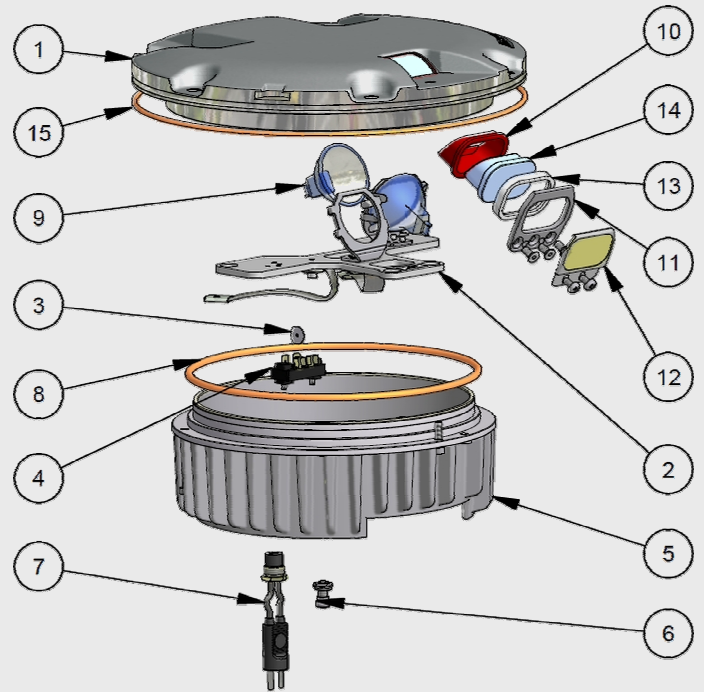
**ACCESSORIES**

- 315.1230 Base L-868 type, class IA, size B, 24" deep *
- 315.1420 Flange ring with pavement dam for L-868 base, size B, with O-Ring and bolts
- 152.8110 Shallow base, 12" dia., one cable lead, with gasket and hardware
- 152.1110 Shallow base, 12" dia., two cable leads, with gasket and hardware
- 712.1012 Setting material for shallow base, 5 lt
- 712.1013 Setting material for shallow base, 20 lt
- 332.4301 Positioning jig for 8"-12" dia. shallow base, without optical device
- 332.4351 Optical device for positioning jig to allow a very precise light unit orientation
- 332.4330 Watertight/shockproof plastic case complete with positioning jig for base and optical device
- 332.4140 Lifting tool (2 pieces to work properly)

* Sectional bases may be required depending upon the paving technique

For any information about isolating transformers and connectors, please see the specific catalogue pages

Shipping Weights and Volumes

	Light Unit	Shallow base
Weight (kg)	7.5	7.3
Volume (m ³)	0.022	0.022

We reserve the right to change the design or specification data without notice

UC-PU-0093_EN-Rev.F